

14. (A) Linkages - Hinges

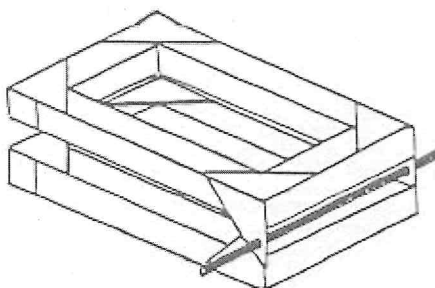

3/16" dowel for hinge

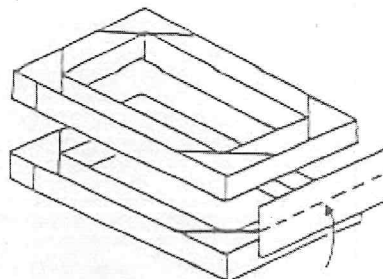

Score care to make a fold

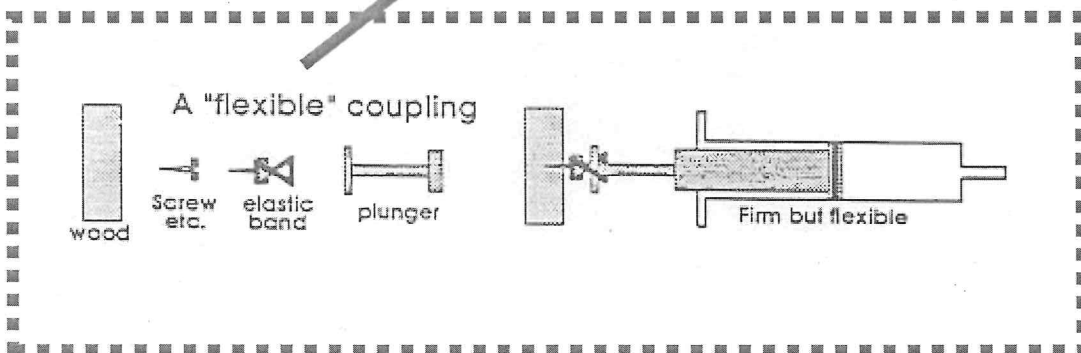
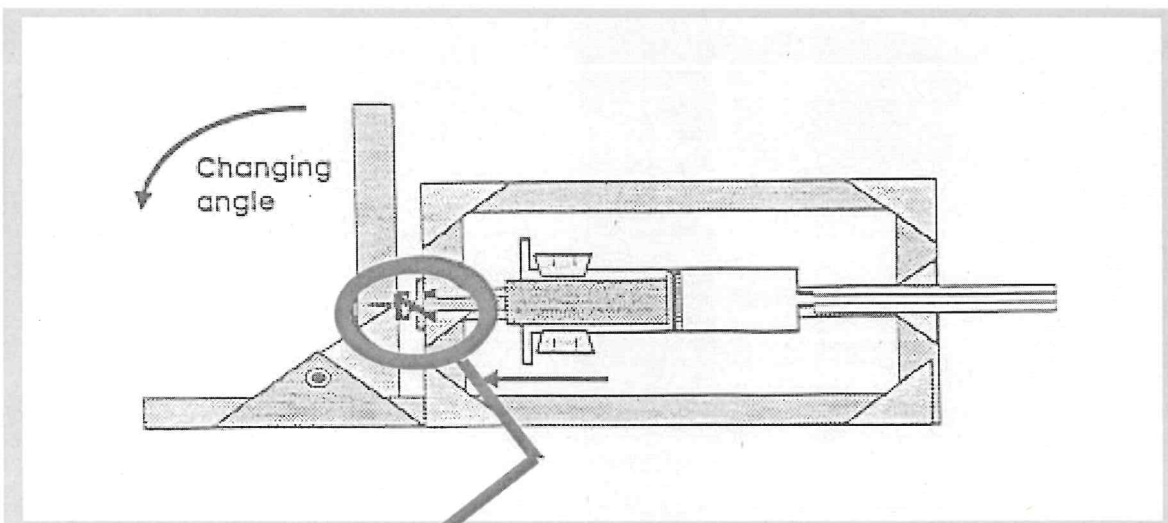
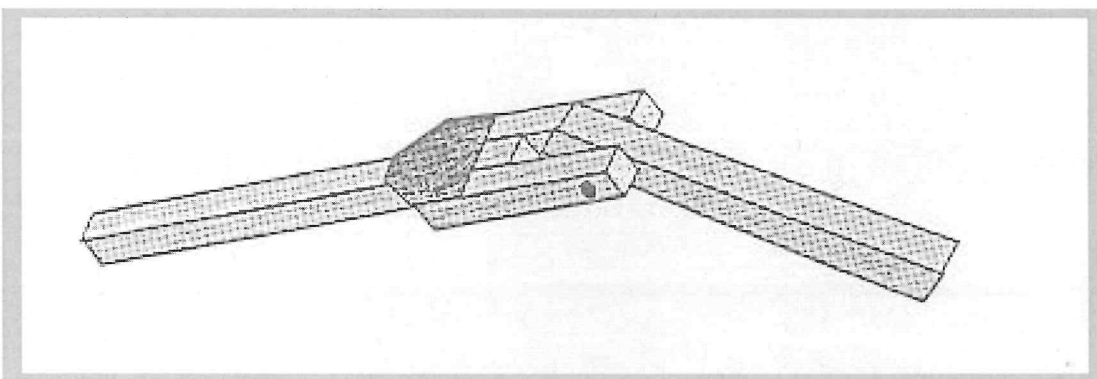

14. (B) Linkages - Elevation

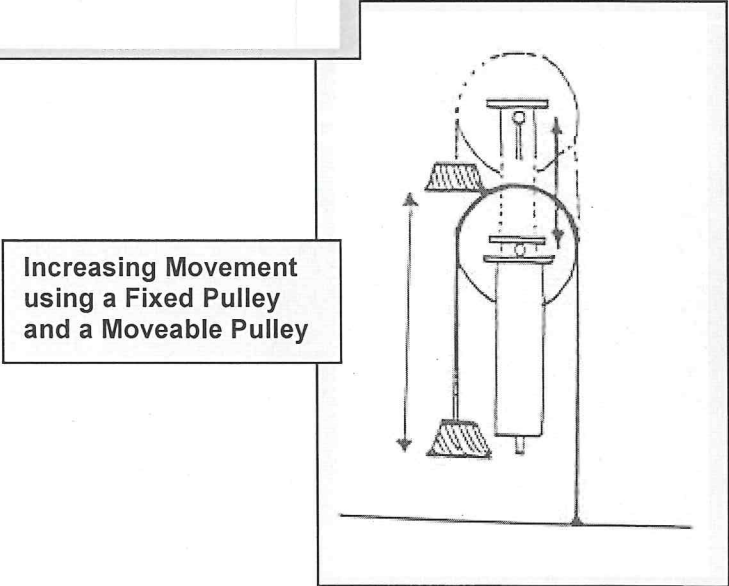
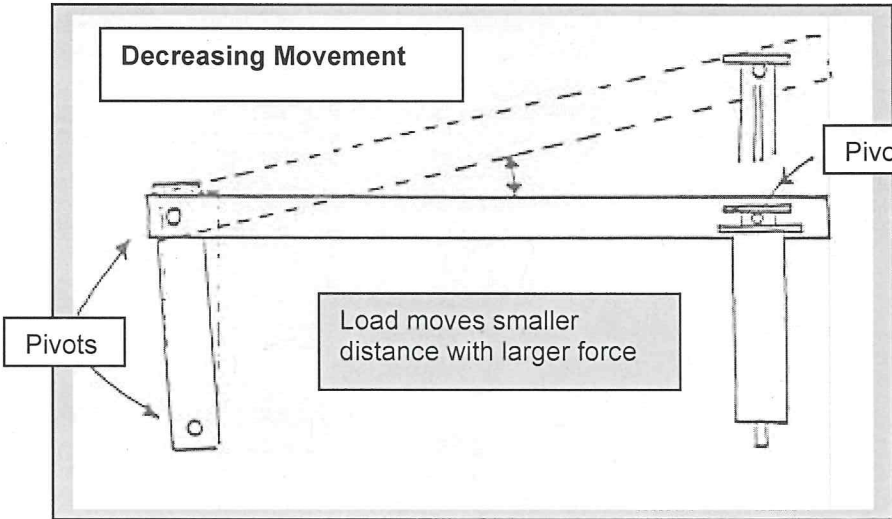
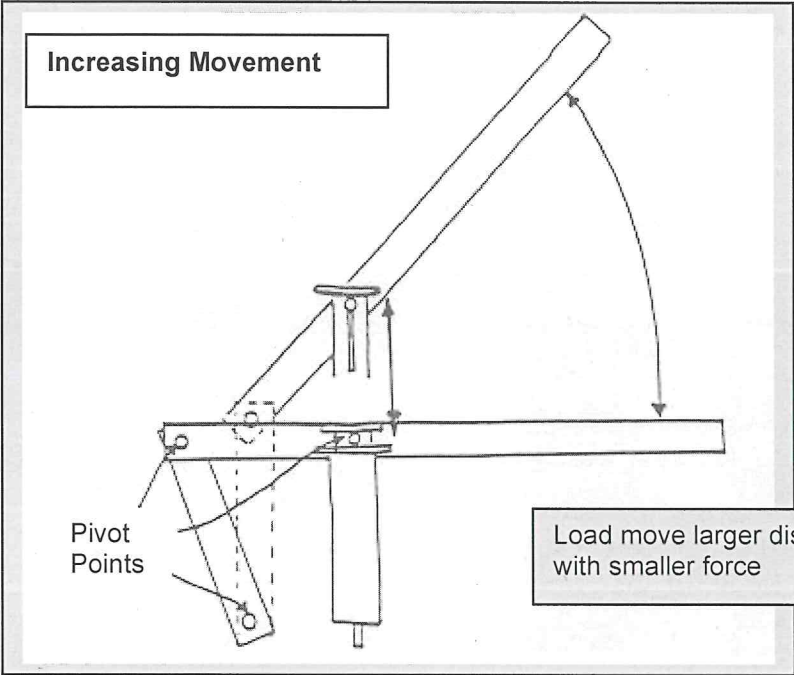

14. (C) Linkages – Rotation

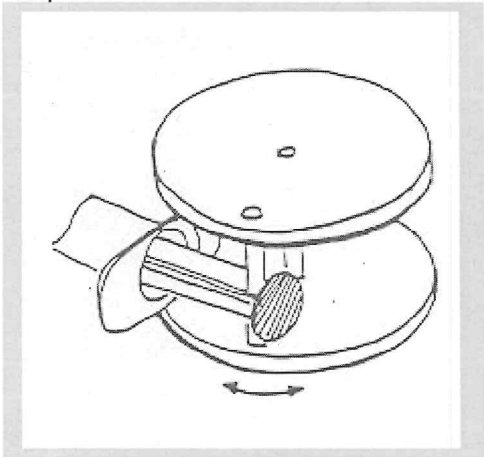
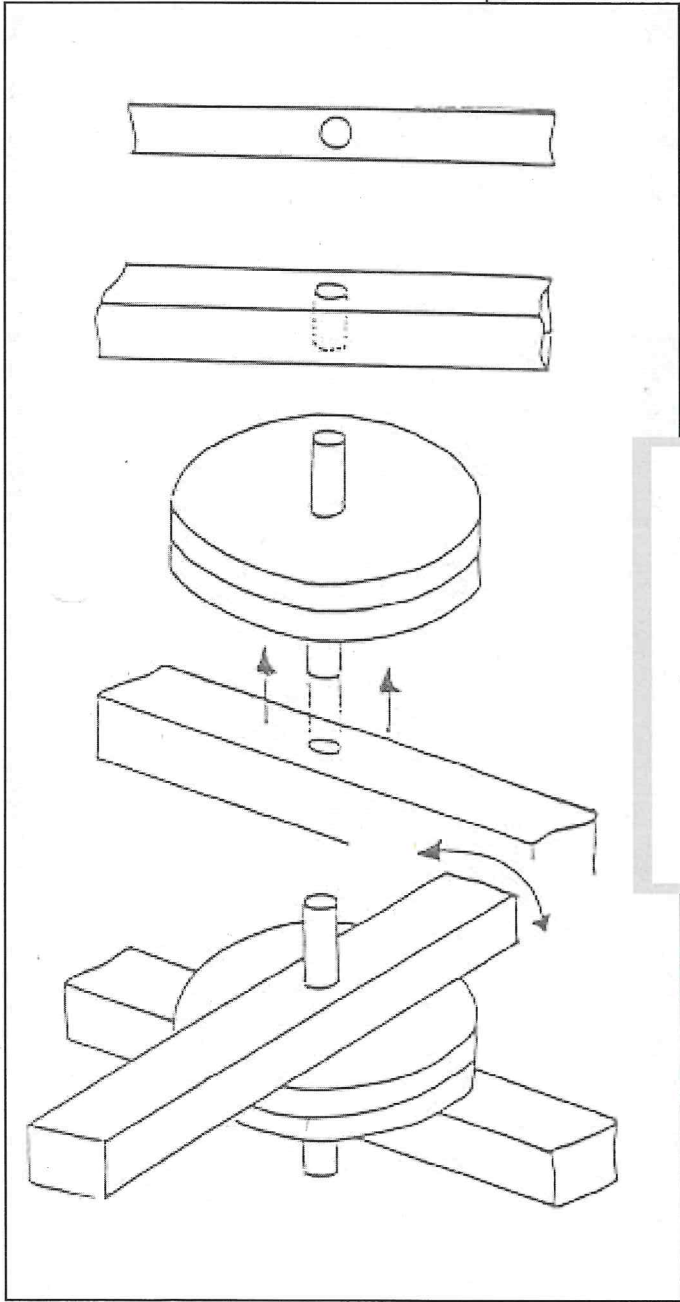
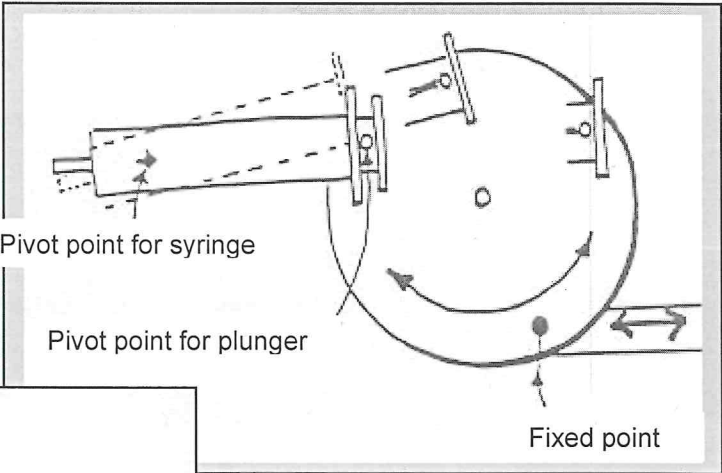

14. (D) LINKAGES – Manipulators

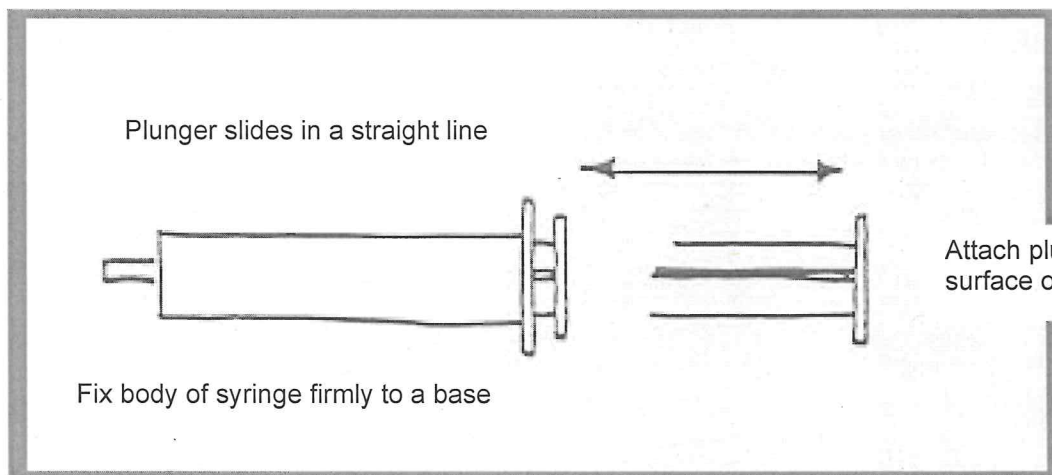
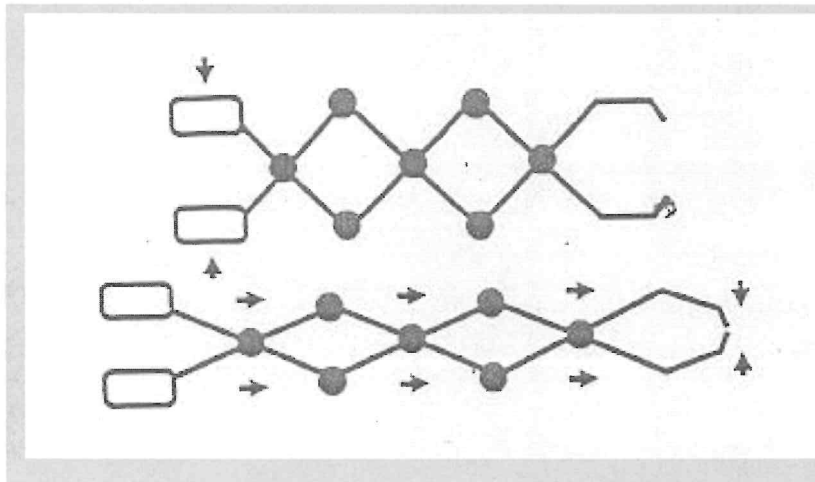
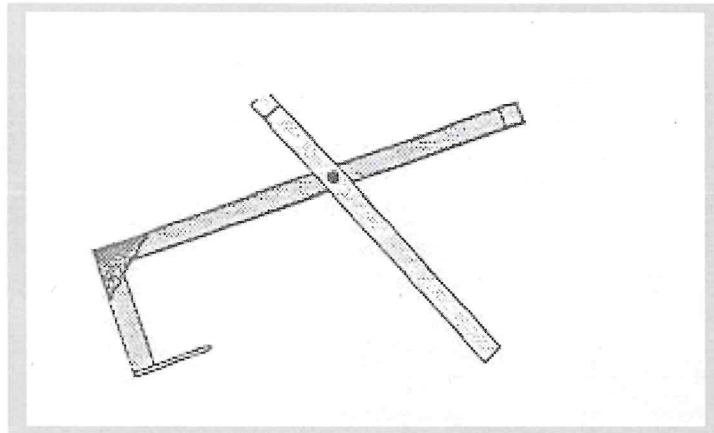

15. Helpful Hints

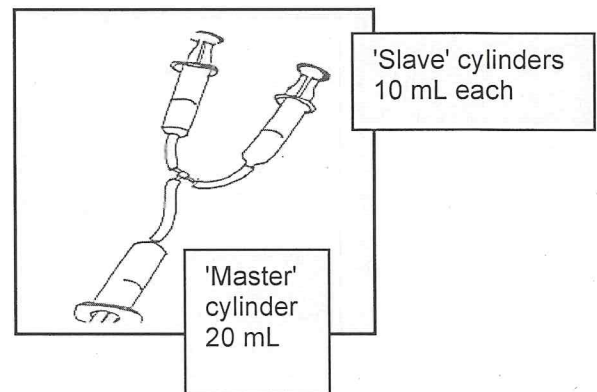
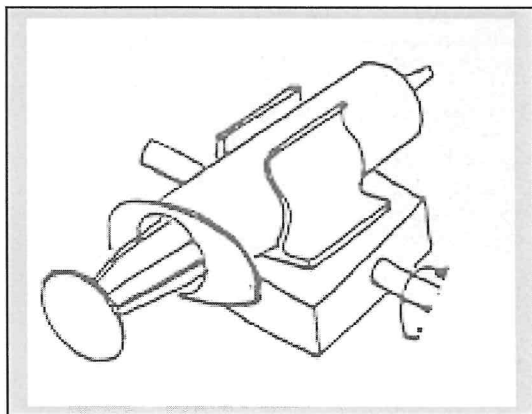
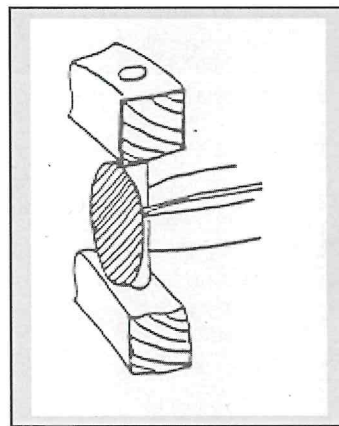
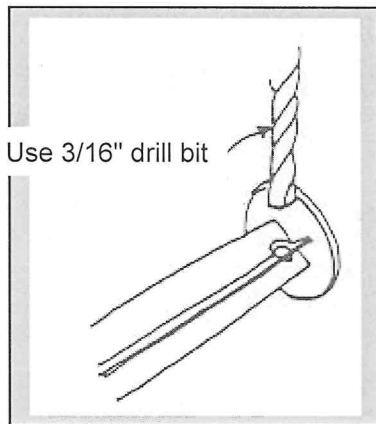
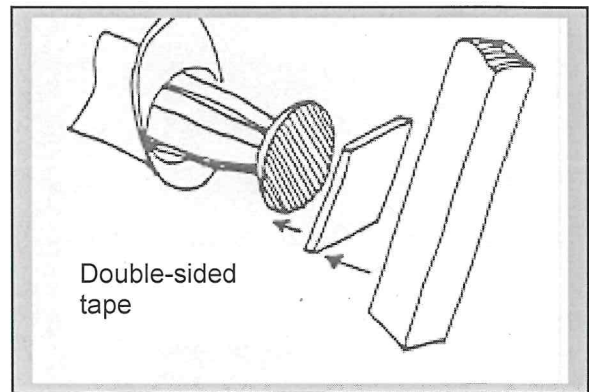
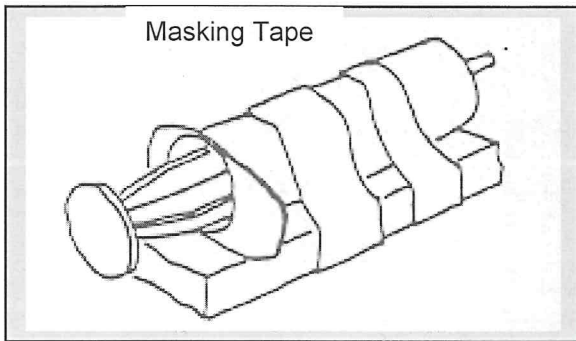
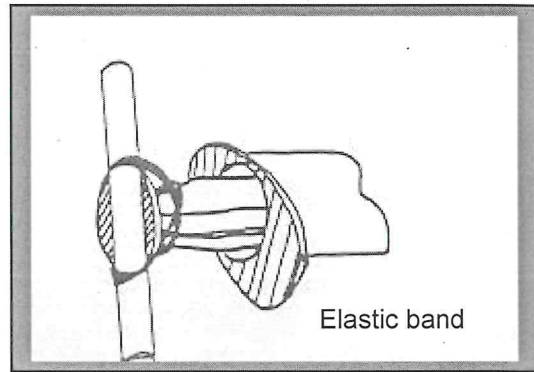
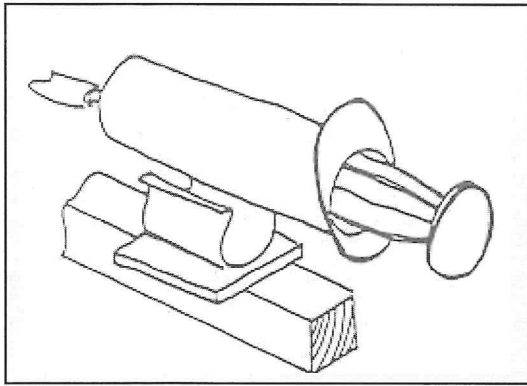

Filling the Syringes with Water

It is important to remove all the air from the syringes and tubing.
To fill – follow the 4 steps below:

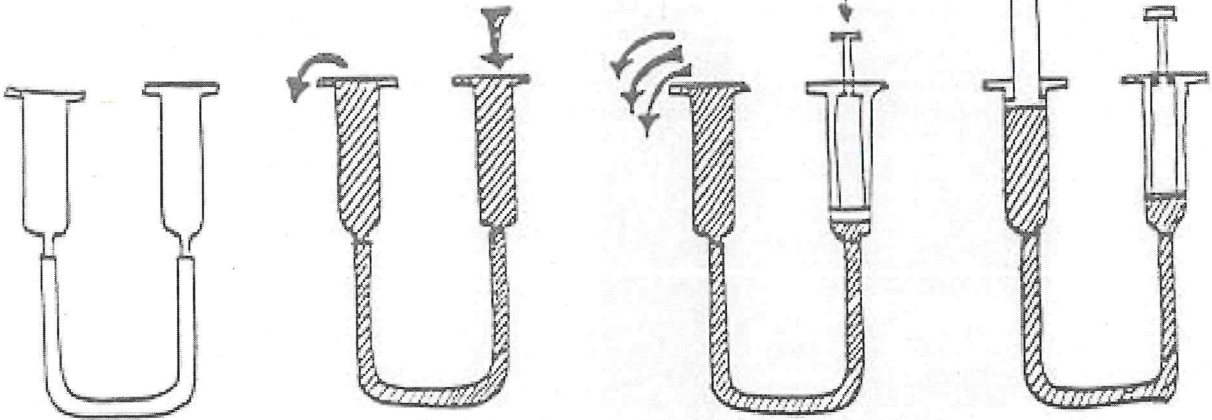

1 – Remove plungers

2 – Fill with water until overflow

3 – Push plunger into one syringe until it is fully inserted

4 – Carefully insert the other plunger

